

---

# **Chap 7 - Spectrum analyzers**

---

### ■ Introduction

- Measurements in the frequency domain tell us how much energy is present at each particular frequency;
- Its are the properly methods for determining the harmonic content of a signal;
- *Fourier theory*
  - mathematical instrument for transforming a time-domain signal into its frequency-domain equivalent representation;
  - any time-domain periodic electrical phenomenon is made up of one or more sine waves of appropriate frequency, amplitude, and phase;
- *Signal spectrum* - is a collection of sine waves that, when combined properly, produce the time-domain periodic signal under examination;
- *Spectrum analysis*
  - type of signal analysis made with amplitudes and without knowing the phase relationships among the sinusoidal components;
  - is complementary to time domain analysis. Some measurements can be made only in the time domain (pure time-domain measurements ).  
Examples: pulse rise and fall times, overshoot, and ringing.

■ Introduction

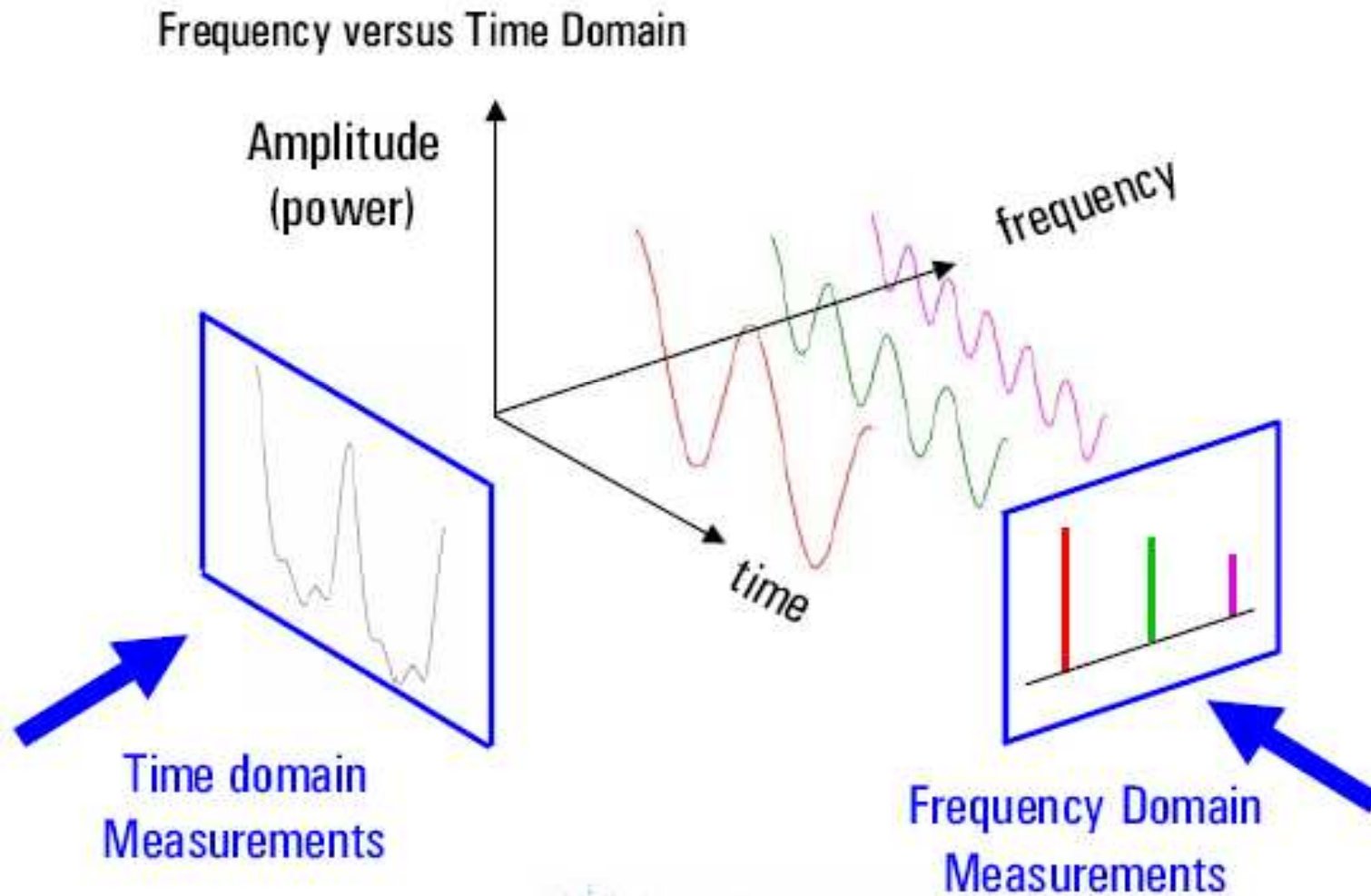

### ■ Fourier Theory - (remember)

A periodic in time domain signal  $x(t) = x(t+T)$  can be expressed as a sum of dc term and a superposition of sinusoidal weighted terms (Harmonic *Fourier Series*)

$$x(t) = a_0 + \sum_{n=1}^{\infty} [a_n \cdot \cos(2\pi n f_0 t) + b_n \cdot \sin(2\pi n f_0 t)]$$

$f_0 = 1/T$  is the fundamental frequency of the waveform

$a_0, a_n, b_n$  are given by:

$$a_0 = \frac{1}{T} \int_{\delta}^{\delta+T} x(t) dt, \quad a_n = \frac{2}{T} \int_{\delta}^{\delta+T} x(t) \cos(2\pi n f_0 t) dt, \quad b_n = \frac{2}{T} \int_{\delta}^{\delta+T} x(t) \sin(2\pi n f_0 t) dt$$

The Fourier Series in complex form is given by:

$$x(t) = \sum_{n=-\infty}^{\infty} c_n e^{j2\pi n f_0 t}, \quad \text{where } c_n = \frac{1}{T} \int_{\delta-T/2}^{\delta+T/2} x(t) e^{j2\pi n f_0 t} dt$$

$$c_n = a_n - j b_n = |c_n| \cdot e^{j\theta_n} = \sqrt{a_n^2 + b_n^2} e^{j\theta_n}, \quad \text{with } \theta_n = \tan^{-1}(-b_n/a_n)..$$

## ■ Fourier Theory (cont'd)

For non-periodic the frequency content of the signal can be estimated through *Fourier Transform* (derived from the limiting case of *Fourier Series* for  $T \rightarrow \infty$ )

$$\mathcal{F}\{x(t)\} = X(j\omega) = \int_{-\infty}^{\infty} x(t) \cdot e^{-j\omega t} dt = |X(j\omega)| \cdot e^{j\varphi(\omega)}, \quad \varphi(\omega) = \tan^{-1} \left( \frac{\Im\{X(j\omega)\}}{\Re\{X(j\omega)\}} \right)$$

$|X(j\omega)|$  is the amplitude spectral density in [V/Hz]

$\varphi(\omega)$  is the associate phase angle

$|X(j\omega)|^2$  constitutes the normalized energy spectral density [J/  $\Omega \cdot$ Hz].

Thus, by integrating  $|X(j\omega)|^2$  over frequency range ( $f_1, f_2$ ) it will yield the mean normalized energy of signal in bandwidth ( $BW = f_2 - f_1$ );

For signal transformation from frequency domain to the time domain it must be used the *Inverse Fourier Transform*:

$$x(t) = \frac{1}{2\pi} \int_{-\infty}^{\infty} F(j\omega) \cdot e^{j\omega t} d\omega.$$

■ Fourier Theory (cont'd)

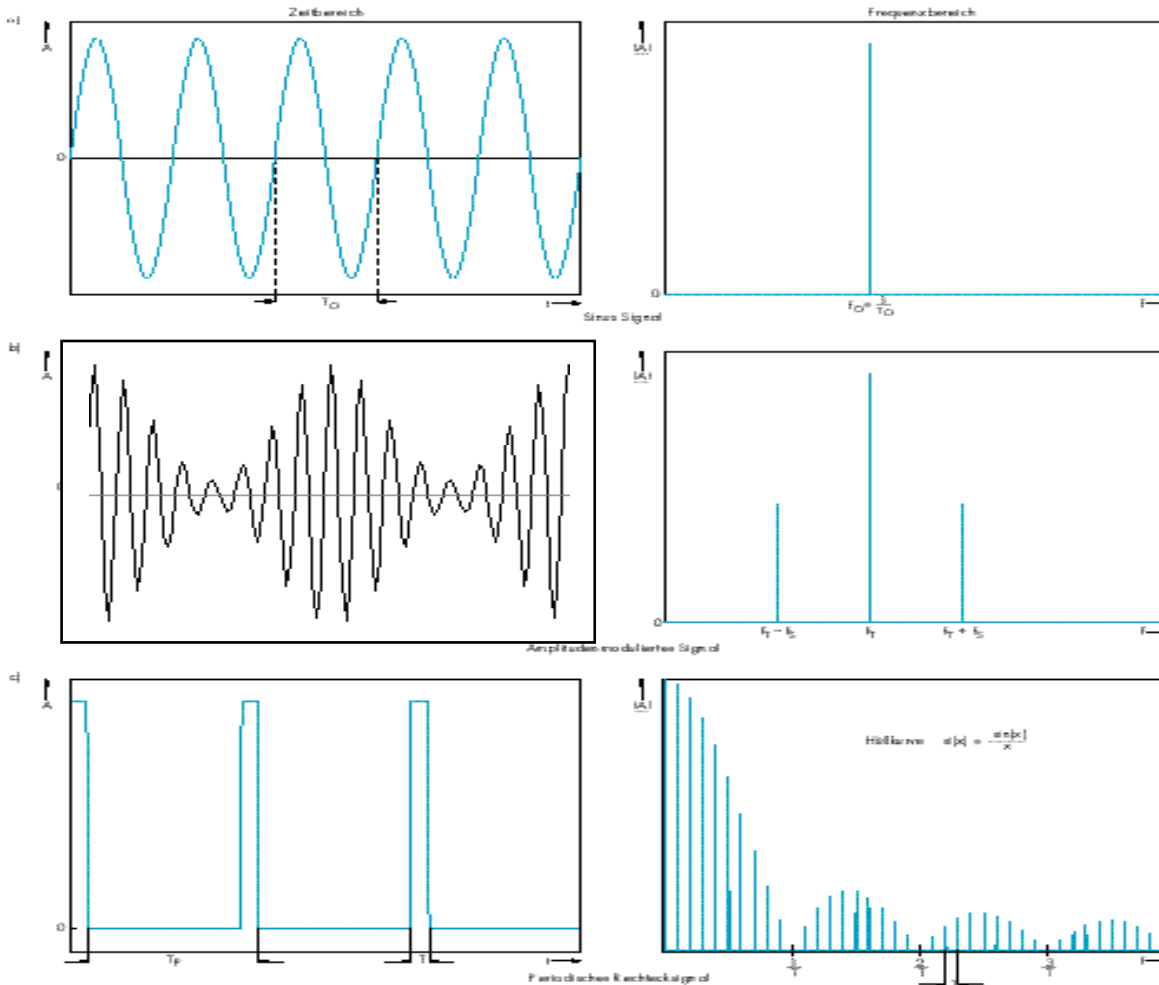

Unmodulated sinewave

AM modulated signal

Periodic rectangular pulse

■ **Fourier Theory (cont'd)**

Note:

$$X(jf) = \int_{-\infty}^{\infty} x(t) \cdot e^{-j2\pi ft} dt = |X(jf)| \cdot e^{j\phi(f)} \quad ; \quad x(t) = \int_{-\infty}^{\infty} X(jf) \cdot e^{j2\pi ft} df$$

<i>Waveform</i>	<i>Time domain <math>x(t)</math></i>	<i>Frequency domain <math>F(jf)</math></i>
Constant	1	$\delta(f)$
Impulse at $t=t_0$	$\delta(t-t_0)$	$e^{-j2\pi ft_0}$
Rectangular	$\Pi\left(\frac{t}{T}\right)$	$T \cdot Sa(\pi fT)$ <sup>[1]</sup>
Triangular	$\Lambda\left(\frac{t}{T}\right)$	$T \cdot [Sa(\pi fT)]^2$
Phasor	$e^{j(\omega_0 t + \varphi)}$	$e^{j\varphi} \delta(f - f_0)$
Sinusoid	$\cos(\omega_c t + \varphi)$	$\frac{1}{2} e^{j\varphi} \delta(f - f_c) + \frac{1}{2} e^{-j\varphi} \delta(f + f_c)$

<sup>[1]</sup>  $Sa(x) = \frac{\sin(x)}{x}$

## EIM Chap 7 – Spectrum analyzer

### ■ Fourier Theory (cont'd) – Examples of non-periodic signals

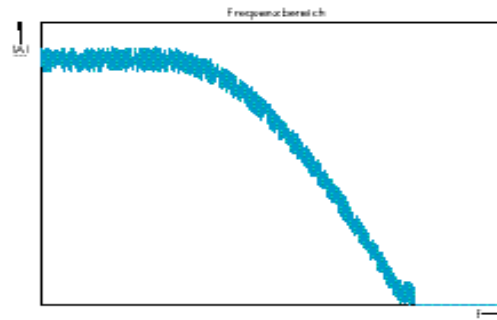
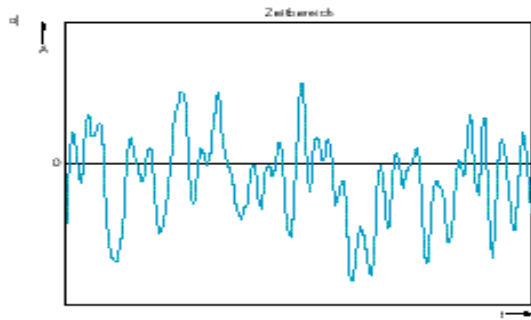

Band-limited random noise

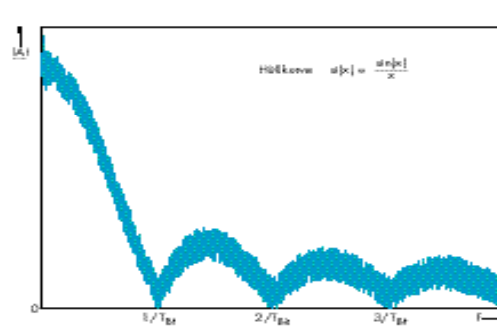
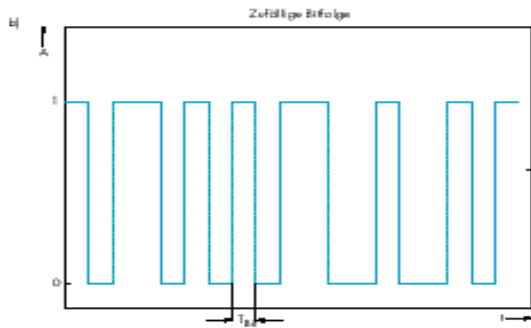

Binary data stream

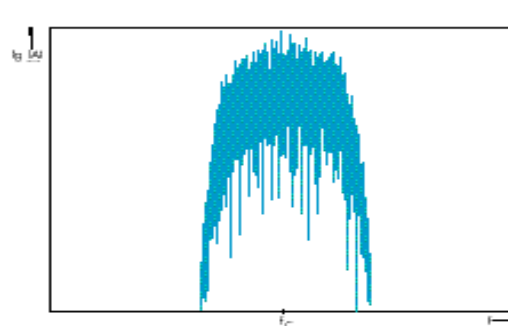
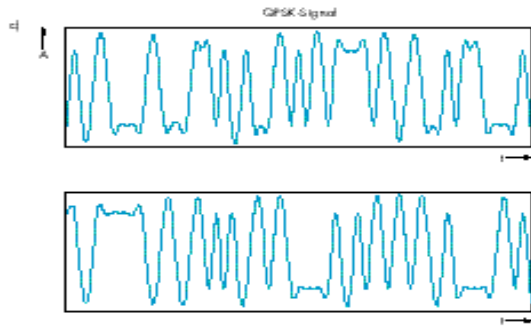

QPSK signal



## ■ Spectrum measurement utilities

### Performances

- level range -60dBm ... +30dBm
- frequencies : <1Hz ... 325GHz (2008)

### Application in:

- spectrum signal display;
- measurement of out-band emissions
- radio spectrum monitor
- measurement of signal harmonics
- measurement of signal bandwidth
- measurement of output signal power ( in a certain bandwidth)
- measurement of *spurious emissions*

(exp: limited bandwidth mobile wireless communications - too little power may mean the signal cannot reach its intended destination, too much power may drain batteries rapidly, create distortion and spatial interferences. Out-band , spurious *or* harmonics emissions can cause frequency interferences with neighbors frequency channels);

## ■ Spectrum analyzer

- the vertical axis is calibrated in amplitude (linear or logarithmic - dB)

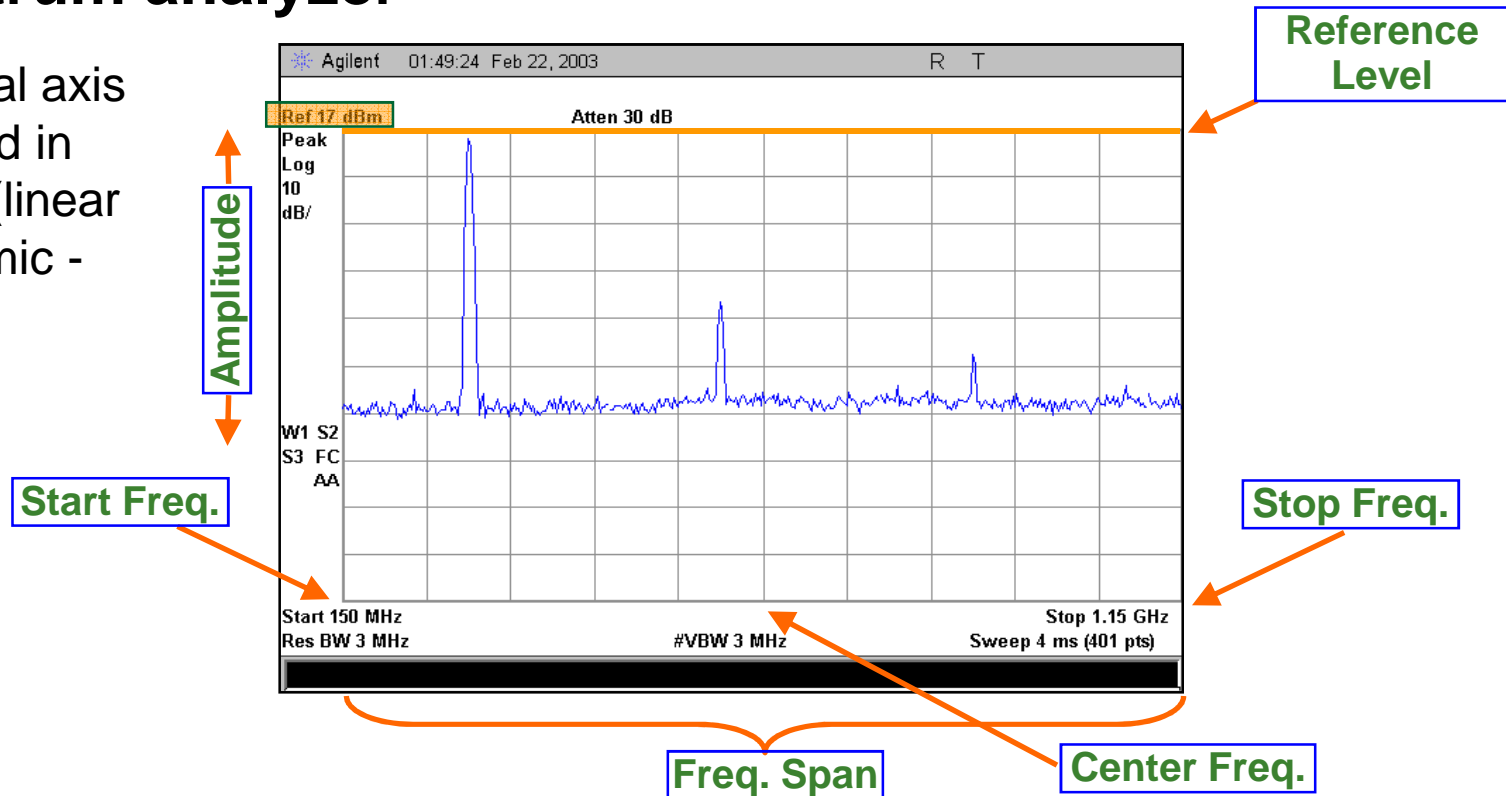

- the horizontal axis is logarithmically calibrated in frequency that increases from left to right

■ **Spectrum analyzer parameters:**

- Start frequency – minimum frequency in viewed spectrum;
- Stop frequency – maximum frequency in viewed spectrum;
- Center frequency – centered frequency value, between start and stop frequency;
- Frequency span – displayed range of frequency;
- Amplitude – sine term amplitude in Fourier series (for periodic or quasi-periodic signal); usually measured in dB. (dBm, dB $\mu$ )
- Reference level – 0 dB level;
- Resolution bandwidth (RBW) – resolution in frequency domain; it is the ability of a spectrum analyzer to separate two input sinusoids into distinct display responses. It is determined by bandwidth of filter centered on intermediate frequency;
- Video bandwidth (VBW) – adjusting display clearance (bandwidth of video filter);
- Sweep (SWP) – sweep time of frequency range (minimum refresh time of displaying);

## ■ Types of signal analyzers

### Swept-tuned Spectrum Analyzer (superheterodyne) - SSA

- An *analogue* spectrum analyzer uses basically a variable bandpass filter, whose mid-frequency is automatically tuned (swept) through the range of frequencies of which the spectrum is to be measured;
- The analyzer measures the signal power from bandwidth selected by bandpass filter;
- Advantages:
  - faster for large frequency range;
  - higher frequency measurement capabilities;
  - large input level range of signals;

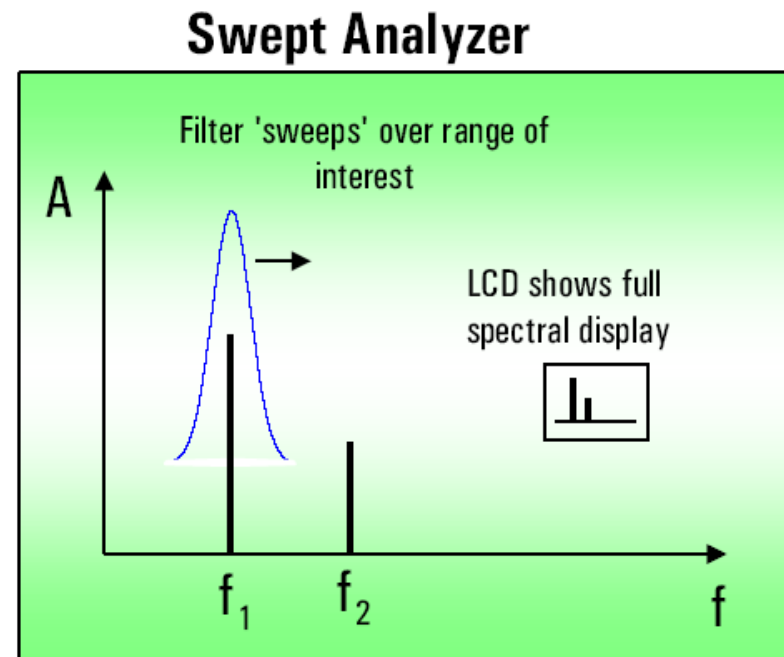

## ■ Types of signal analyzers

### Fourier Spectrum Analyzer

- A *digital* spectrum analyzer uses the Fast Fourier Transform (FFT), to resolve a waveform into its compositions of complex frequencies (thus both amplitude and phase information is available) in the frequency domain. The demanding calculations are performed by powerful DSPs, using fasters and lowest complexity algorithms;
- It doesn't use the filters;
- Advantages:
  - faster for small frequency range;
  - phase measurement capabilities;
  - modulation possibilities;

### Fourier Analyzer

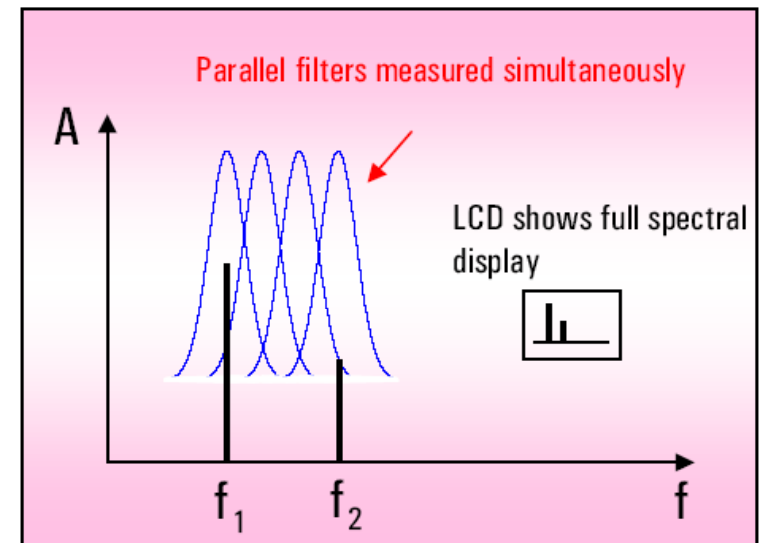

## Types of signal analyzers

### Vector Signal Analyzer

- Vector signal analyzers adopt the FFT algorithm to show the phase domain of a signal at certain defined points in time;
- They extend the capabilities to the RF frequency range using downconverters in front of the digitizer;
- They offer fast, high-resolution spectrum measurements, demodulation, and advanced time-domain analysis (useful for complex signals such as burst, transient or modulated signals used in communications);
- In simple cases, when the modulation mode and the encoding scheme are known, the analysis can be done in real time;

A. QPSK signal

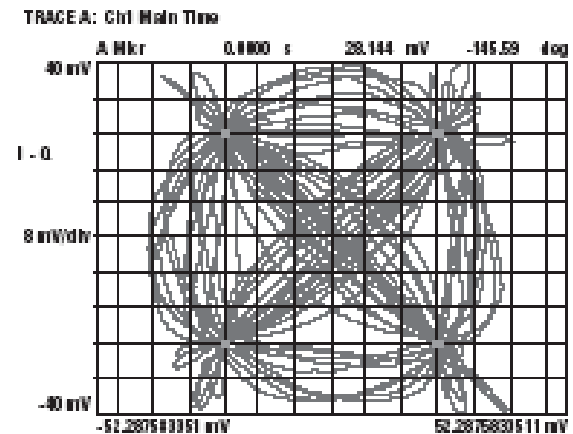

B. 16QAM signal

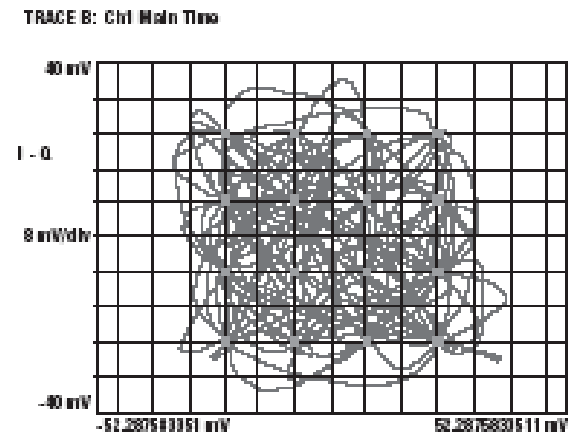

## EIM Chap 7 – Spectrum analyzer

### ■ Swept-tuned Spectrum Analyzer – principle of operation

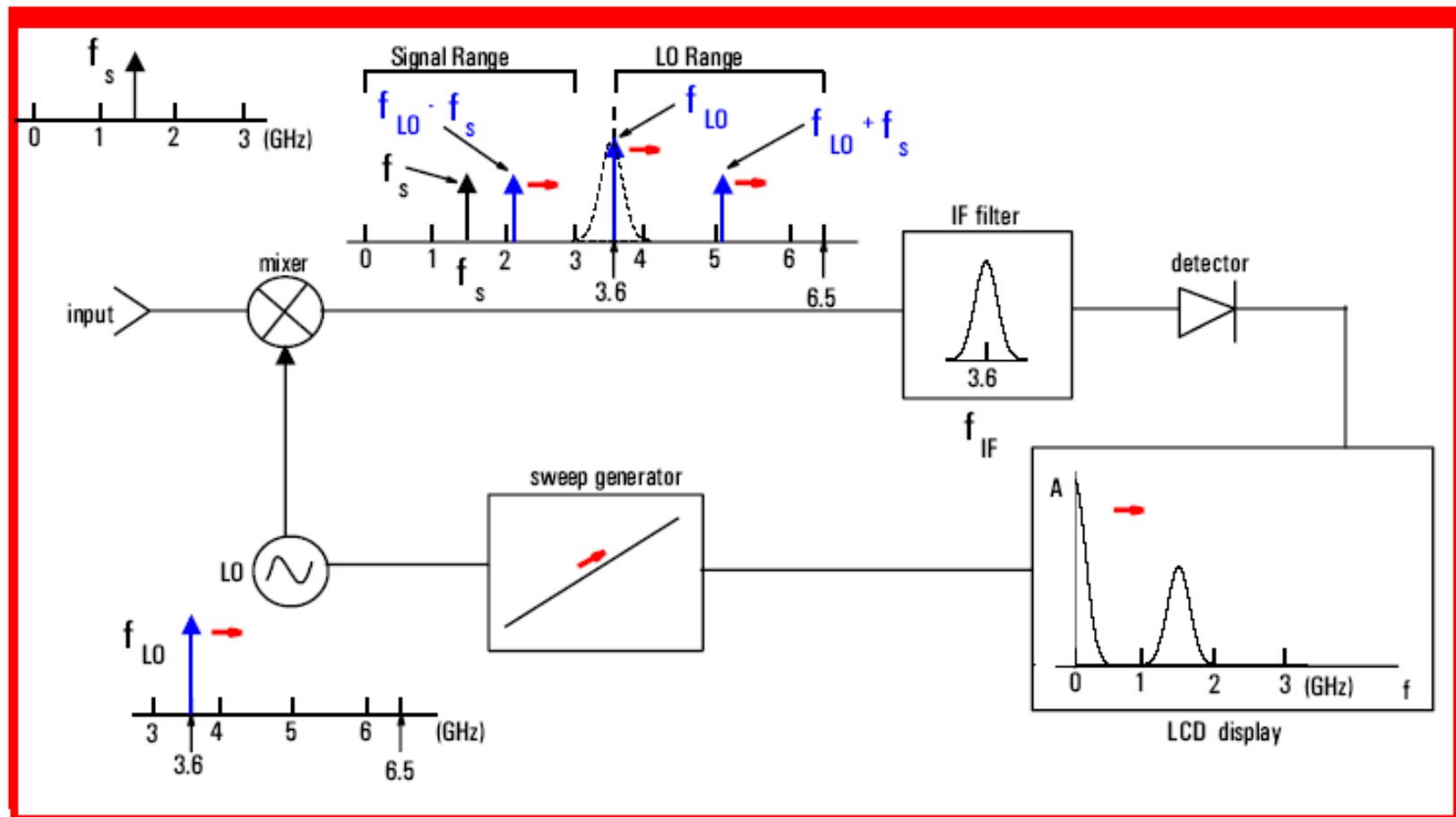

■ SSA (cont'd)

**Block diagram of a classic superheterodyne spectrum analyzer**

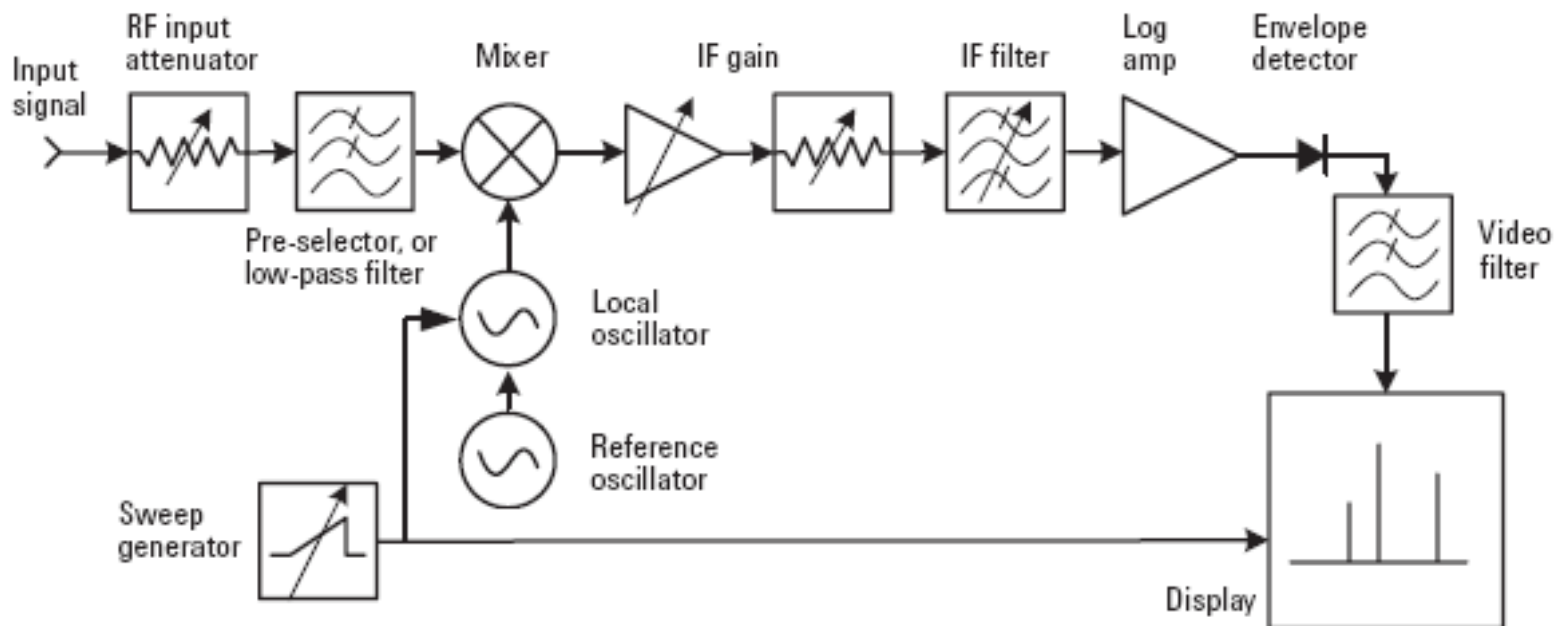

Superheterodyne - translate signal frequency (mix) to frequencies above the audio range;



■ **SSA (cont'd)**

An input signal passes through an attenuator, then through a low-pass filter to a mixer, where it mixes with a signal from the local oscillator (LO). If any of the mixed signals falls within the pass-band of the intermediate-frequency (IF) filter, it is further processed (amplified and perhaps compressed on a logarithmic scale), then rectified by the envelope detector, digitized, and displayed.

A ramp generator creates the horizontal movement across the display from left to right. The ramp also tunes the LO so that its frequency change is in proportion to the ramp voltage;

The output of a spectrum analyzer is an X-Y trace on a display. The horizontal axis is linearly calibrated in frequency that increases from left to right. Setting the frequency is a two-step process:

1. adjust the frequency at the centerline of the graticule (center frequency);
2. adjust the frequency range (span) across the full display;

The vertical axis is calibrated in amplitude: a linear scale is calibrated in volts or a logarithmic scale is calibrated in dB.

■ **SSA (cont'd)**

- **RF Input attenuator:** its purpose is to ensure the signal enters the mixer at the optimum level to prevent overload, gain compression, and distortion.

The blocking capacitor is used to prevent the analyzer from being damaged by a DC signal or a DC offset of the signal.

The input block can be easy burn.

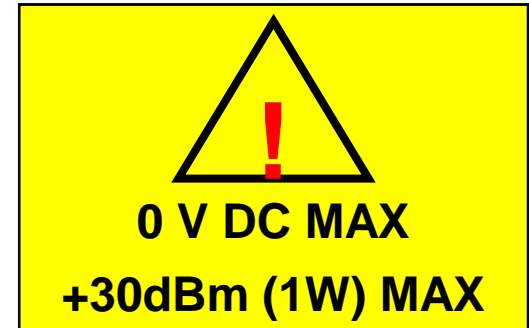

- **Low-pass filter or preselector:**

The low-pass filter blocks high frequency signals from reaching the mixer to prevent out-of-band signals from mixing with the local oscillator and creating unwanted responses at the IF;

- **Intermediate amplifier:** adjusts level of signal after mixer to maintain the reference level position on the display when RF attenuator is changed;

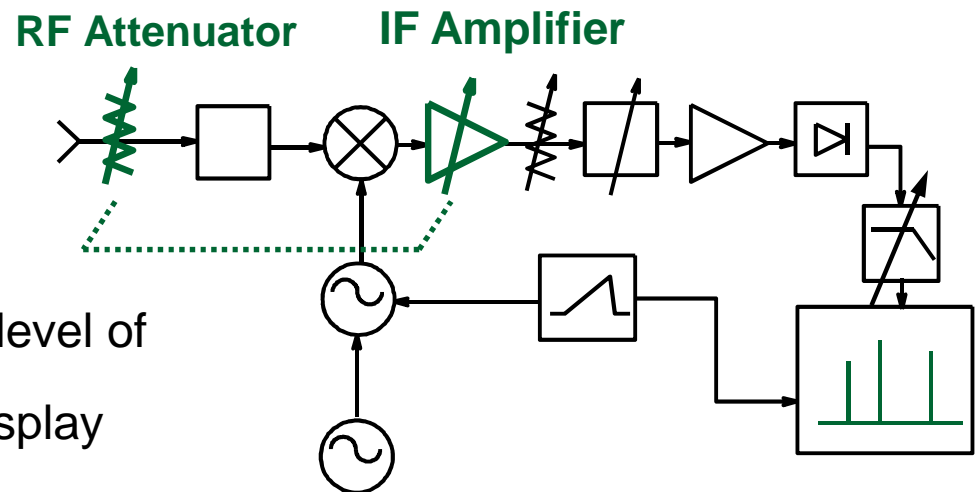

■ **SSA (cont'd)**

- **Mixer:** translates the input signal to a frequency range of intermediate filter that the SSA can filter, amplify and detect. It mixes the input signal  $f_s$  with a locally produced frequency  $f_{LO}$  thus resulting in the sum and difference frequencies to appear at its output.

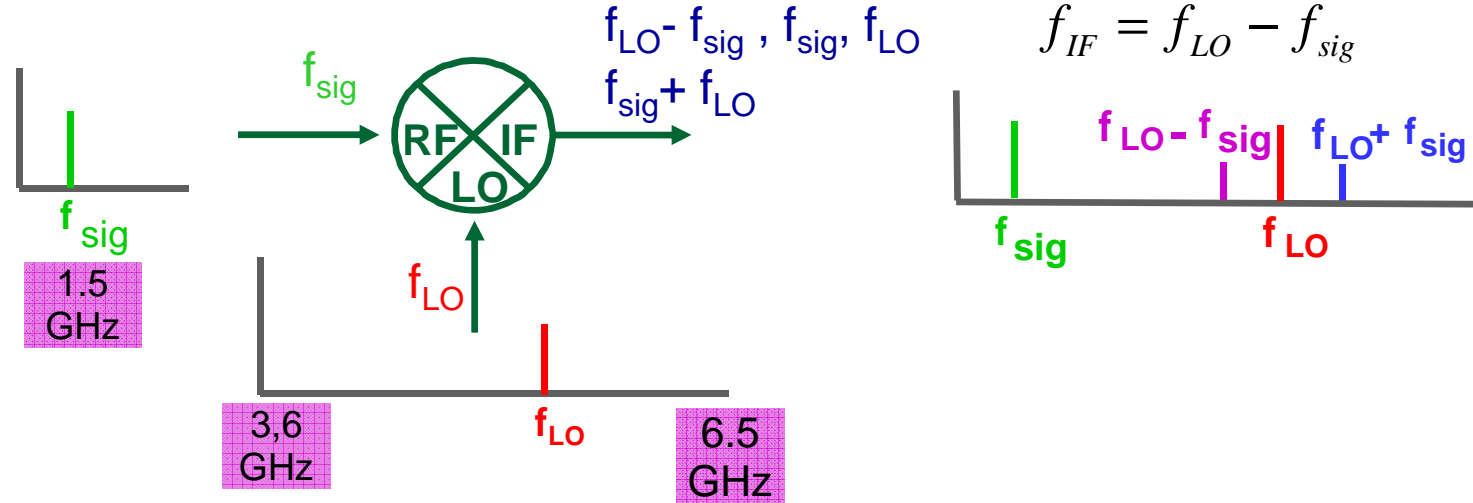

For  $f_{IF}=3.6\text{GHz}$  and  $f_{sig\_util}=0\dots2.9\text{GHz} \rightarrow f_{LO}=3.6 \dots 6.5\text{GHz}$

But  $f_{sig\_imag}=7.2 \dots 10.1\text{GHz}$  and  $f_{LO}=3.6 \dots 6.5\text{GHz} \rightarrow f_{out}=3.6\text{GHz}$

It is mandatory LPF before mixer to attenuate external signal on image frequency.

■ SSA (cont'd)

- **Local Oscillator (LO):** it is a voltage controlled oscillator whose frequency is determined by the sweep generator.
- **Sweep generator:** in addition to controlling the frequency of the LO, it controls the horizontal deflection of the SSA display and depending on the voltage range of the ramp and the sweep time it determines the SSA resolution.

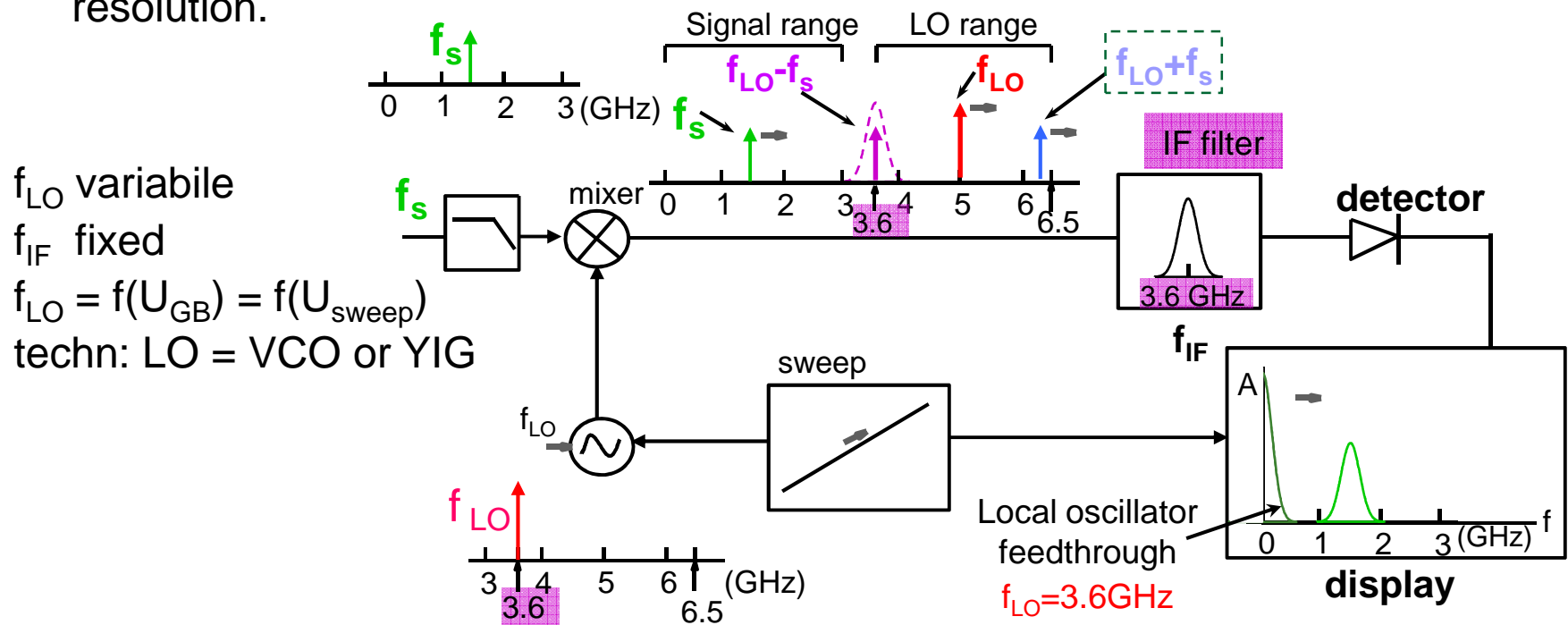

■ SSA (cont'd)

- **Intermediate Frequency (IF) filter:** it is a fixed band pass filter whose 3-dB bandwidth determines the resolution bandwidth (RBW) of the SSA. It is preceded by a variable gain unit which is tied to the input attenuator, so that the correct frequency amplitude can be displayed. The typical IF bandwidth is about 10Hz – 1kHz.

nearly Butterworth filter shape:

$$\left| \frac{H(f)}{H(f_{IF})} \right|_{dB} = -10 \cdot \log_{10} \left[ Q^{2n} \left( \frac{f}{f_{IF}} - \frac{f_{IF}}{f} \right)^{2n} + 1 \right]$$

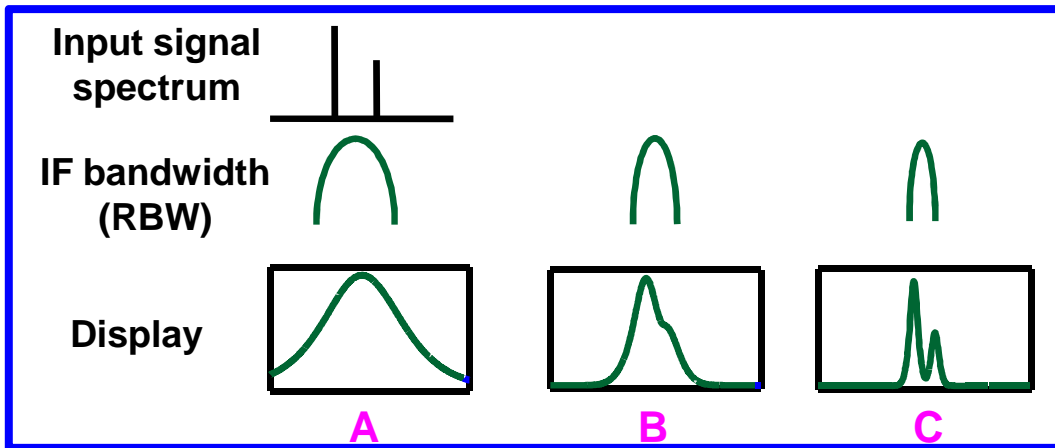
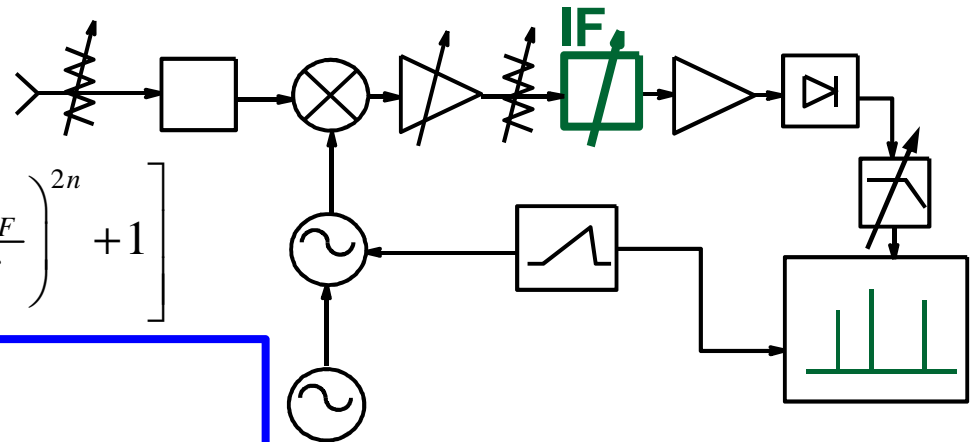

$H(f)$  is the filter shape transfer function  
 $n$  is the number of filter poles  
 $f_{IF}$  is the central frequency of filter  
 $Q$  is quality factor of filter

## ■ Frequency resolution of SSA

- Is determined by IF filter shape
- RBW selectivity is ability of distinguish two sine wave of **different amplitude**
- *Bandwidth selectivity*, ratio of 60 dB to 3 dB IF bandwidths
  - Usually: maximum = 15:1 for analogue IF filter, maximum=5:1 for digital IF filter;
  - Some analyzers, take a hybrid approach, using analog filters for the wider bandwidths and digital filters for bandwidths of 300 Hz and below.

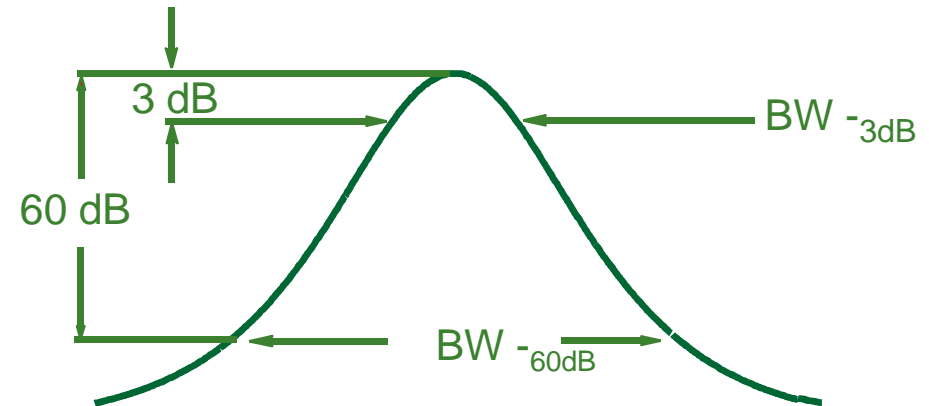

$$\text{Selectivity} = \frac{\text{BW}_{-60\text{dB}}}{\text{BW}_{-3\text{dB}}}$$

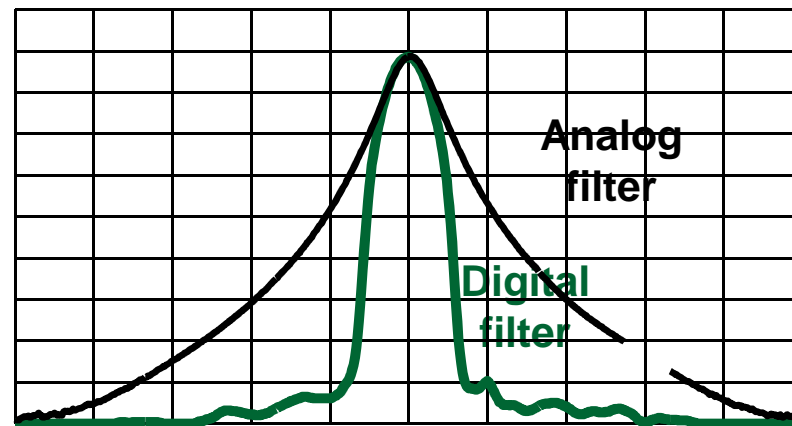

■ Frequency resolution of SSA

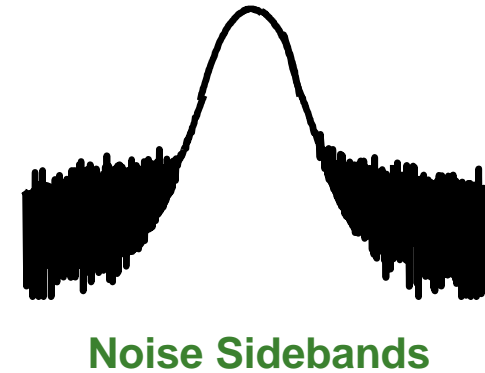
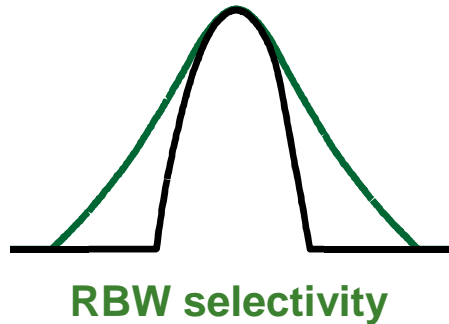
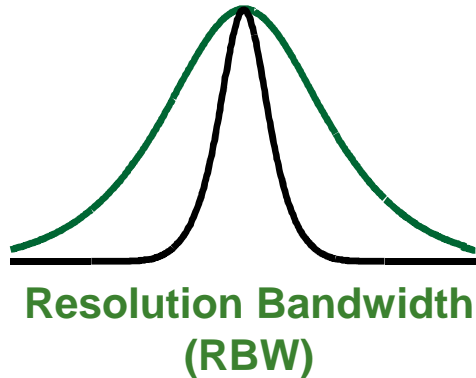

- ability of distinguish two sine wave signal with **equal amplitudes**;

- $RBW = B_{-3dB}$  (-3dB IF filter bandwidth);

Example:  $RBW = 10\text{KHz}$  permits two sine wave identification, that are  $10\text{KHz}$  frequency separation.

If  $f_{IF} = 3.9\text{GHz} \Rightarrow Q = \frac{f_{IF}}{B_{-3dB}} = 390000$   
unrealizable

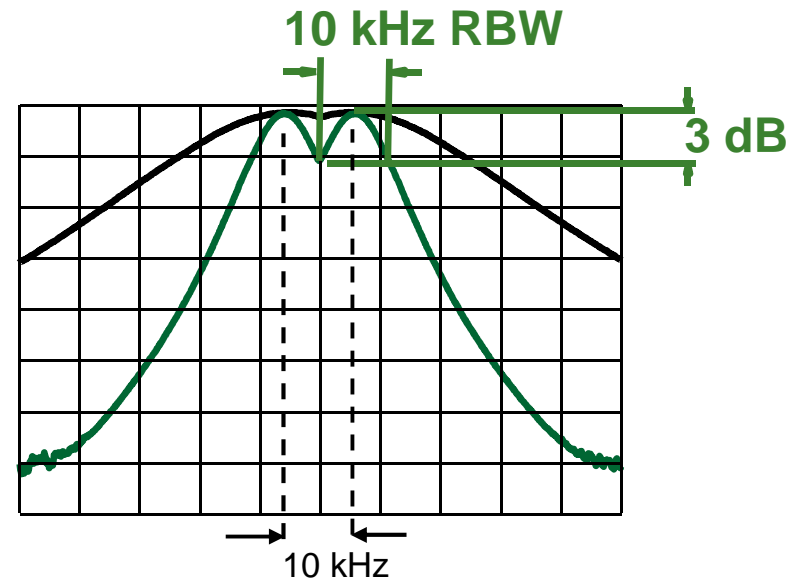

## ■ Frequency resolution of SSA

- resolution improving with multiple mixers (2...4 conversions);
  - only LO1 is voltage commanded by Sweep Gen., and LO2, LO3, ... are fixed;
  - $f_s = f_{LO1} - (f_{LO2} + f_{LO3} + f_{IF3}) \rightarrow f_{LO1} = [f_{IF1} + f_{s \min}, f_{IF1} + f_{s \max}]$ ;
  - $f_{IF1} = f_{LO2} + f_{LO3} + f_{IF3}$  and  $B_{-3dB \ IF1} > B_{-3dB \ IF2} > B_{-3dB \ IF3}$ , but  $RBW = B_{-3dB \ IF3}$
- Example:  $f_s = 0 \dots 3 \text{GHz}$ ,  $f_{LO2} = 3.6 \text{GHz}$ ,  $f_{LO3} = 300 \text{MHz}$ ,  $f_{IF3} = 21.4 \text{MHz}$ ,  $Q = 2140$ ;

$$RBW = B_{-3dB \ IF3} = 10 \text{kHz}$$

Result:

$$f_{IF2} = f_{LO3} + f_{IF3} = 321,4 \text{MHz}$$

$$B_{-3dB \ IF2} = 150 \text{KHz}$$

$$f_{IF3} = f_{LO2} + f_{IF2} = 3.9214 \text{GHz}$$

$$B_{-3dB \ IF1} = 1.83 \text{MHz}$$

$$f_{LO1 \ min} = 3.9214 \text{GHz}$$

$$f_{LO1 \ max} = 6.9214 \text{GHz}$$

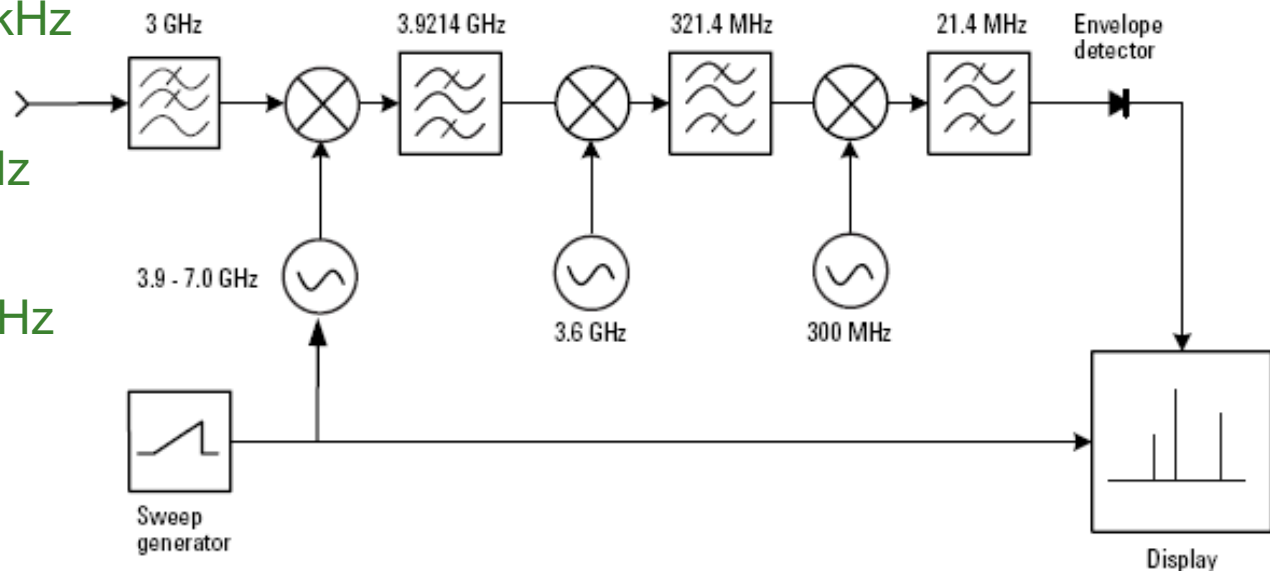



■ Example: RBW selectivity

Conclusion: 2 sine wave with different amplitude (60dB difference) must have frequency separation of  $\frac{1}{2} B_{-60dB}$  to be distinguished;

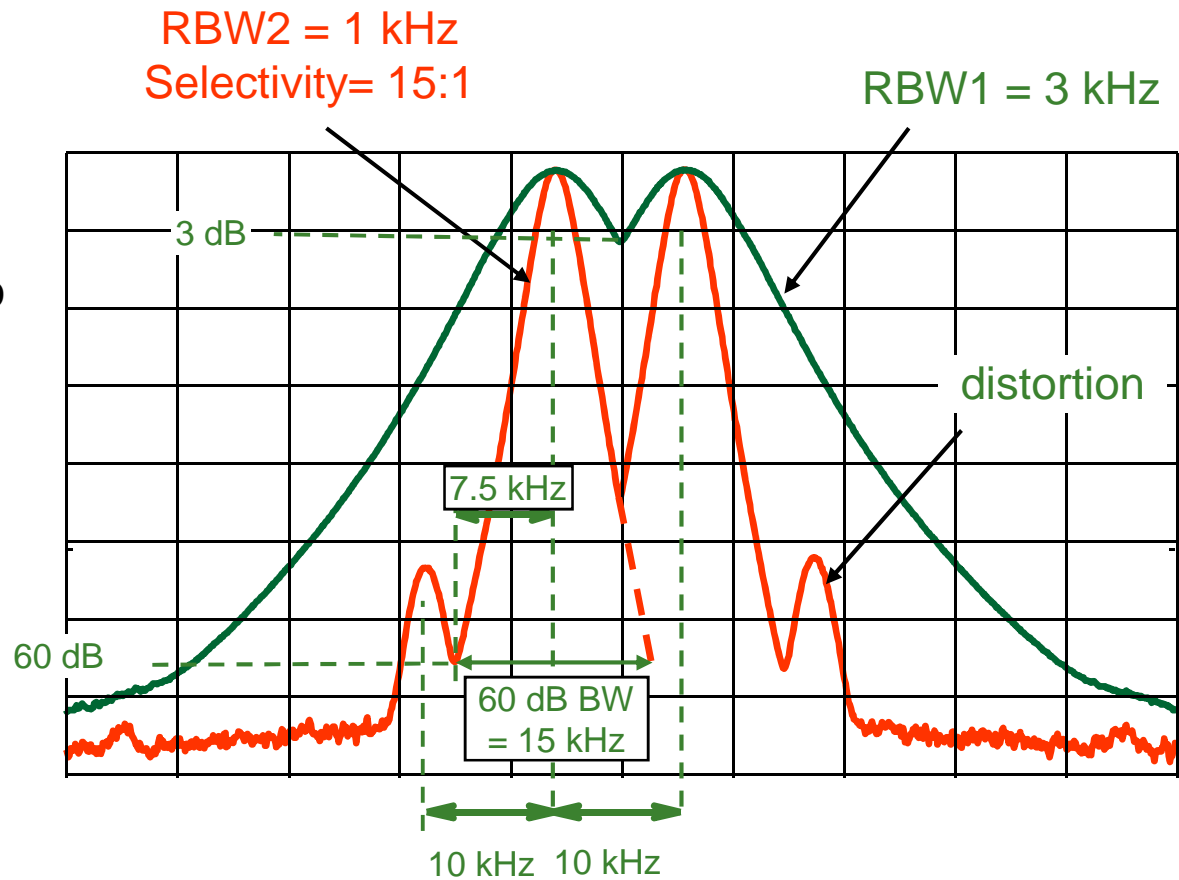

## ■ Residual FM

Also, the resolution of a spectrum analyzer is affected by the stability of the LOs in the analyzer (particularly the first LO).

The first LO is typically a YIG-tuned oscillator (tuning in the 3 to 7 GHz range), that has the residual FM of 1 kHz or more. This instability was transferred to any mixing products and appear around any spectral component displayed on screen, without the possibility to determine whether the input signal or the LO was the source of this instability.

Modern analyzers have dramatically improved residual FM, having residual FM of 2 to 8 Hz, and bandwidths as low as 1 Hz.

So any instability we see on a spectrum analyzer today is due to the incoming signal.

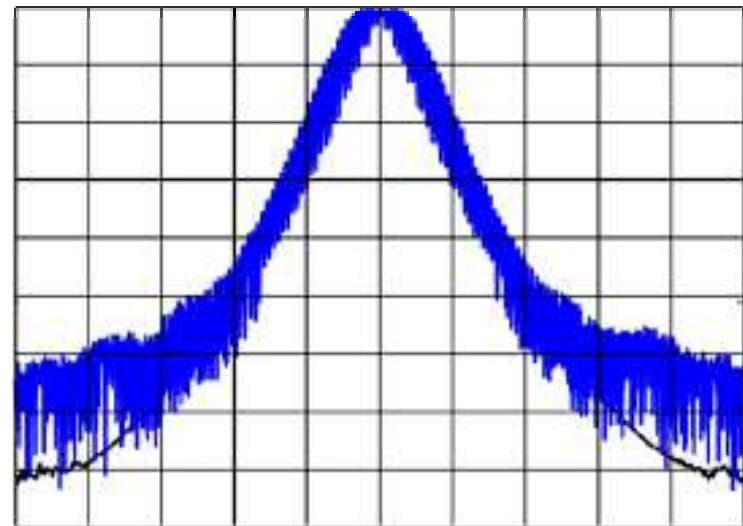

## ■ Phase noise

- Phase noise is displayed only when a signal is displayed far enough above the system noise floor;
- Phase noise is specified in dBc (dB level ratio from carrier level, normalized to RBW)

$$Noise|_{dB} = A_{sig}|_{dB} - 10\log\left(\frac{RBW}{1Hz}\right)$$

Example: Maximum noise level to observe a signal with amplitude  $A_2=A_1-40dB$ , with a frequency offset  $\Delta f=50kHz$ , and  $RBW = 1kHz \rightarrow Noise = A_1-70dB$ .

Reducing the resolution bandwidth by a factor of ten, the level of the displayed phase noise decreases by 10dB.

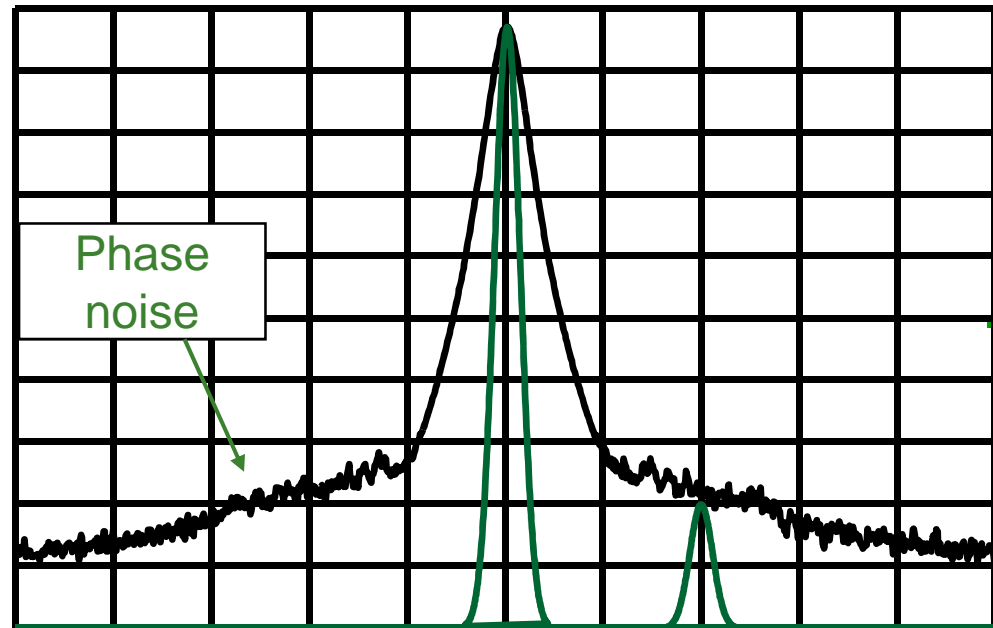

### ■ Phase noise (cont'd)

Some modern spectrum analyzers allow the user to select different LO stabilization modes to optimize the phase noise for different measurement conditions:

- *Optimize phase noise for frequency offsets < 50 kHz from the carrier*

In this mode, the LO phase noise is optimized for the area close in to the carrier at the expense of phase noise beyond 50 kHz offset.

- *Optimize phase noise for frequency offsets > 50 kHz from the carrier*

This mode optimizes phase noise for offsets above 50 kHz away from the carrier, especially those from 70 kHz to 300 kHz. Closer offsets are compromised and the throughput of measurements is reduced.

- *Optimize LO for fast tuning*

When this mode is selected, LO behavior compromises phase noise at all offsets from the carrier below approximately 2 MHz. This minimizes measurement time and allows the maximum measurement throughput when changing the center frequency or span.

## ■ Sweep time

Sweep time represents how long it takes to complete a measurement;

Best resolution - narrowest possible resolution (IF) filter

- $T_d$  = direct sweep time (*sweep time*)
- $T_b$  = IF filter rise time (response time IF)

$$\left. \begin{aligned} \frac{T_d}{T_b} &= \frac{S}{RBW} && \text{S- span frequency} \\ T_b &= \frac{k}{RBW} && \text{; with } k = 2..3 \end{aligned} \right\}$$

$$\Rightarrow T_d = \frac{kS}{(RBW)^2}$$

$$\text{for } VBW < RBW \Rightarrow T_d = \frac{kS}{RBW \cdot VBW}$$

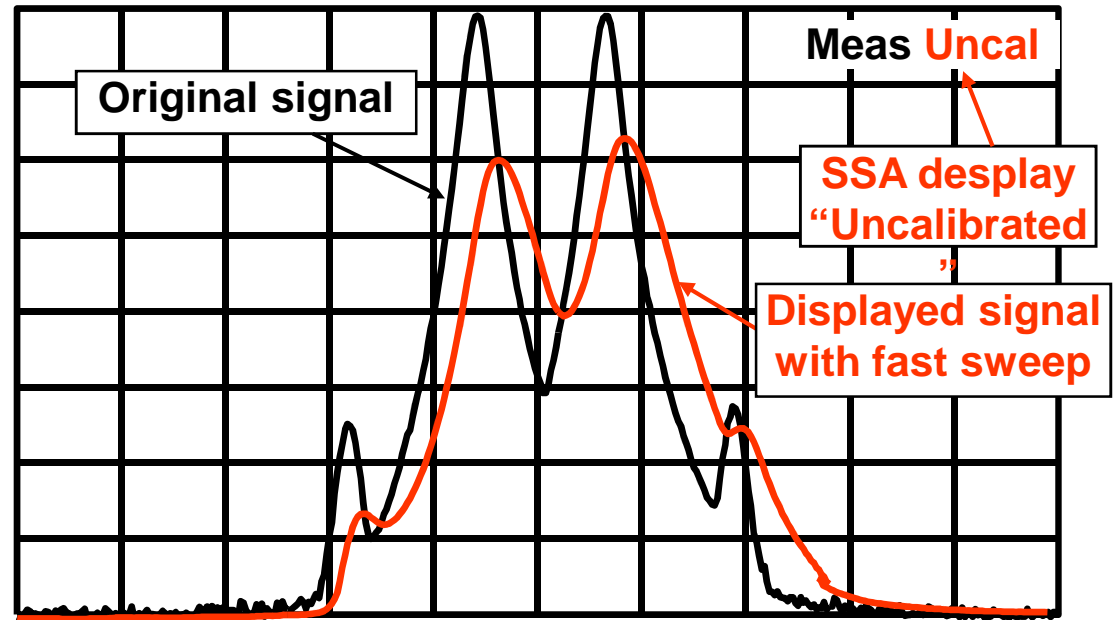

**Sweeping an analyzer too fast causes a drop in displayed amplitude and a shift in indicated frequency**

■ **SSA (cont'd)**

- **Detector:** it is essentially a rectifier whose output follows the peak variations of the IF filter's output. Furthermore, it provides the necessary amplification in order to compensate for mixer losses –as long as the mixer operates in its linear region- so that the spectral components are displayed correctly.

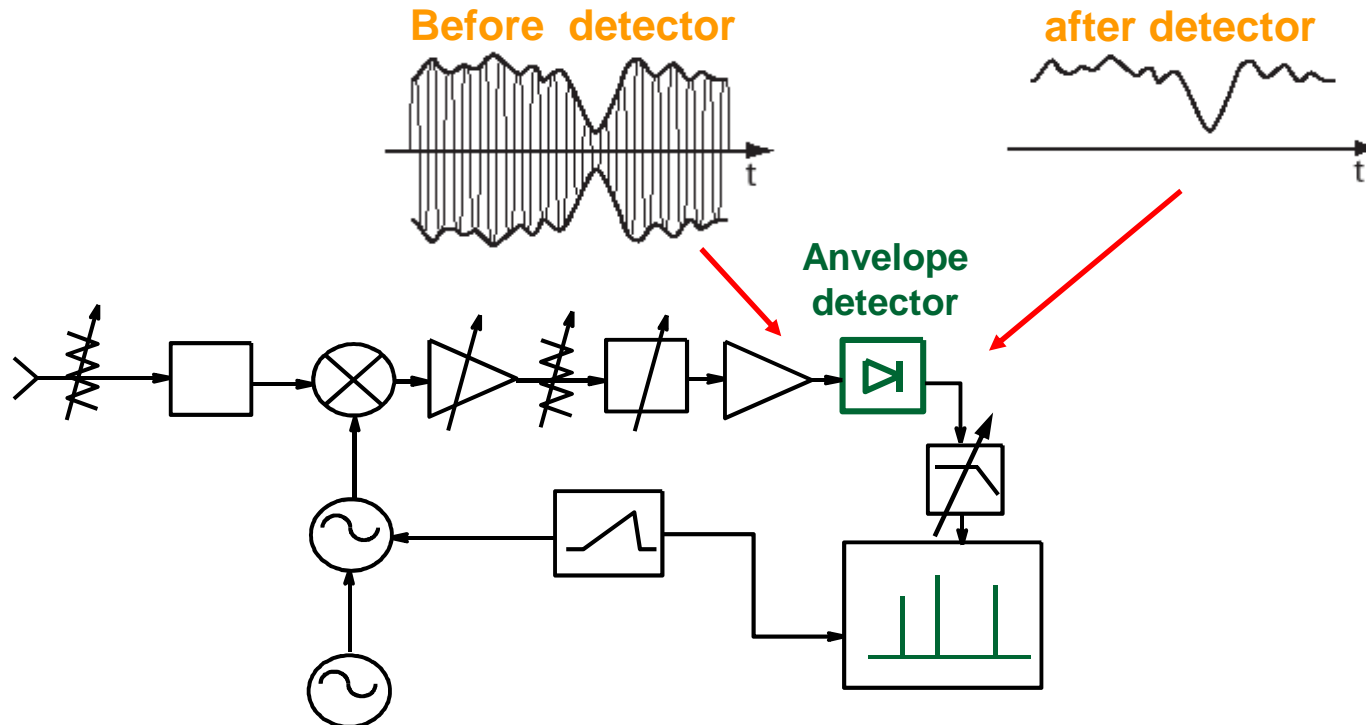

■ **SSA (cont'd)**

- **Video filter:** it is a low-pass filter whose purpose is to smooth the display by filtering out fast fluctuating noise signals. It manages so by averaging the signal.
- **Display:** it is a liquid crystal display, where the spectral components are depicted.

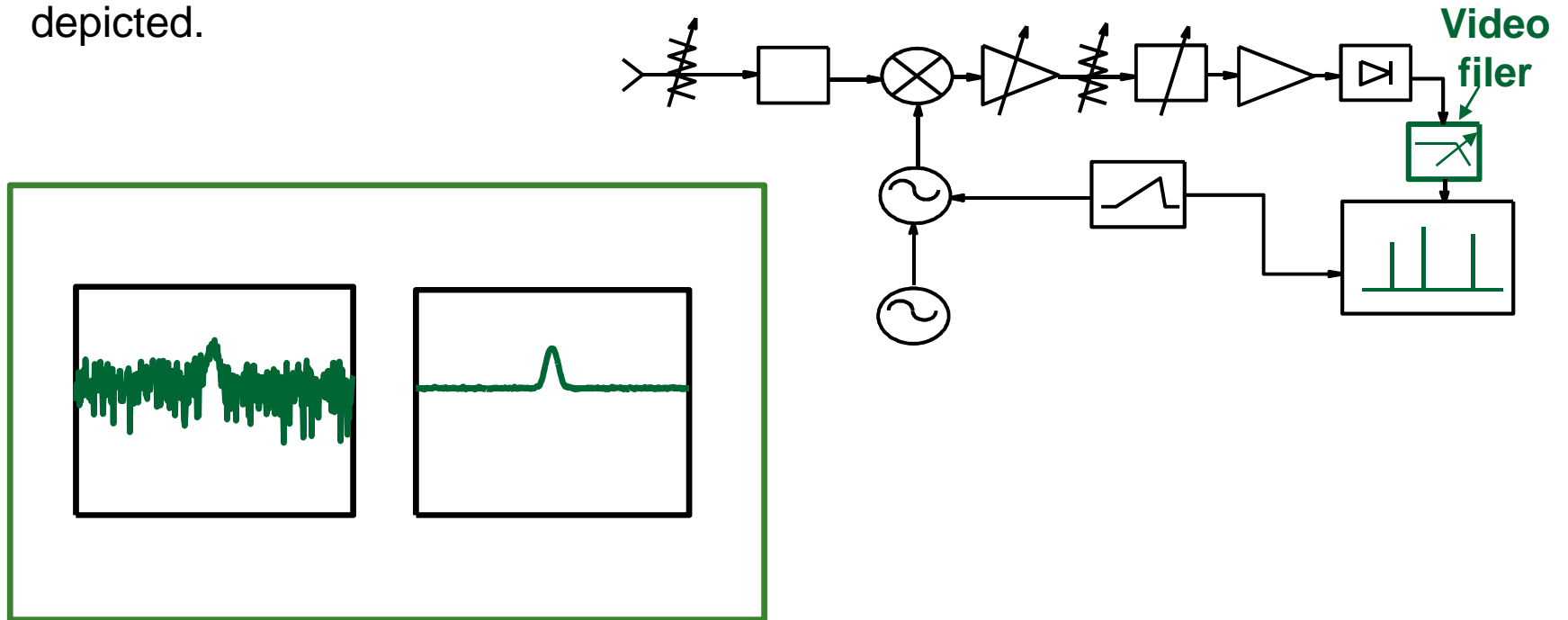

## ■ Detection types

The image displayed are made up from 101 to 8192 points. Each point must represent what has occurred over some frequency range, bucket in frequency (bin). Each bucket contains data from a span and time frame that is determined by equations:

$$\text{frequency : bucket width} = \frac{\text{Span}}{\text{trace points}-1}$$

$$\text{time : bucket width} = \frac{\text{Sweep time}}{\text{trace points}-1}$$

Detection types in one bucket: *sample*, *positive peak*, *negative peak*, *normal*, *average*, *quasi-peak*.

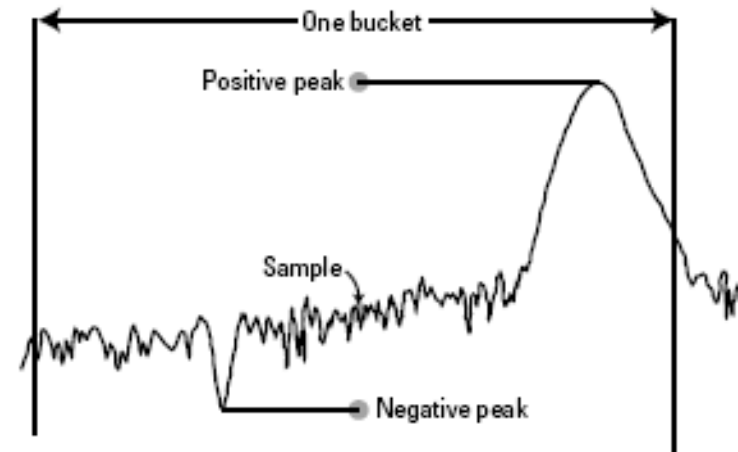



### ■ Detection types

- *Sample detection* - selects the data point as the instantaneous level at the center of each bucket. It is suitable for indicating the randomness of noise, and it is not a good mode for analyzing sinusoidal signals (uses linear interpolation for less points);
- *Positive peak detection* - displays the maximum value encountered in each bucket. It is the default detection mode because it ensures that no sinusoid is missed;
- *Negative peak detection* - displays the minimum encountered value in each bucket. It is used in differentiating continuous wave from impulsive signals in electromagnetic compatibility (EMC) testing.
- *Normal detection* - provides a better visual display of random noise than *peak* and yet avoid the missed-signal problem of the *sample* mode. If the algorithm *rosenfell* algorithm classifies the signal as noise, then the odd-numbered data point displays the maximum value and the even-numbered data point displays the minimum value encountered during its bucket. For sine wave inputs signals, the pos-peak and neg-peak detectors sense an amplitude change in only one direction and maximum value in each bucket is displayed.

## ■ Detection types

- *Average detection* - collect amplitude data many times in each bucket, sample detection keeps only one of those values and throws away the rest. It uses all the data values collected within the time (and frequency) interval of a bucket and average the power, voltage, or log of the signal:
  - *Power (rms) averaging* averages rms levels, by taking the square root of the sum of the squares of the voltage data measured during the bucket interval. Is best for measuring the power of complex signals;
  - *Voltage averaging* averages the linear voltage data of the envelope signal measured during the bucket interval. It is often used in EMI testing for measuring narrowband signals;
  - *Log-power (video) averaging* averages the logarithmic amplitude values (dB) of the envelope signal measured during the bucket interval. It is best for observing sinusoidal signals, especially those near broadband noise.

Others techniques that smooth the variations in the envelope-detected amplitude are *video filtering* and *trace averaging*.

---

### ■ SSA (cont'd)

- Comparison between average and video filtering
- video filter is a LPF that comes after the envelope detector, determines the bandwidth of the video signal and operates in real time, during single sweep; (rising time of filter can requires reducing sweeping speed) ; It reduces peak-to-peak variations of the noise and not sinusoid signal.
- average operates on the data of multiple sweeping operation (it hasn't influence in sweeping speed);

$$A_{\text{avg}} = \frac{n-1}{n} A_{\text{prev avg}} + \frac{1}{n} A_n$$

- the visual effect is the same for broadband noise

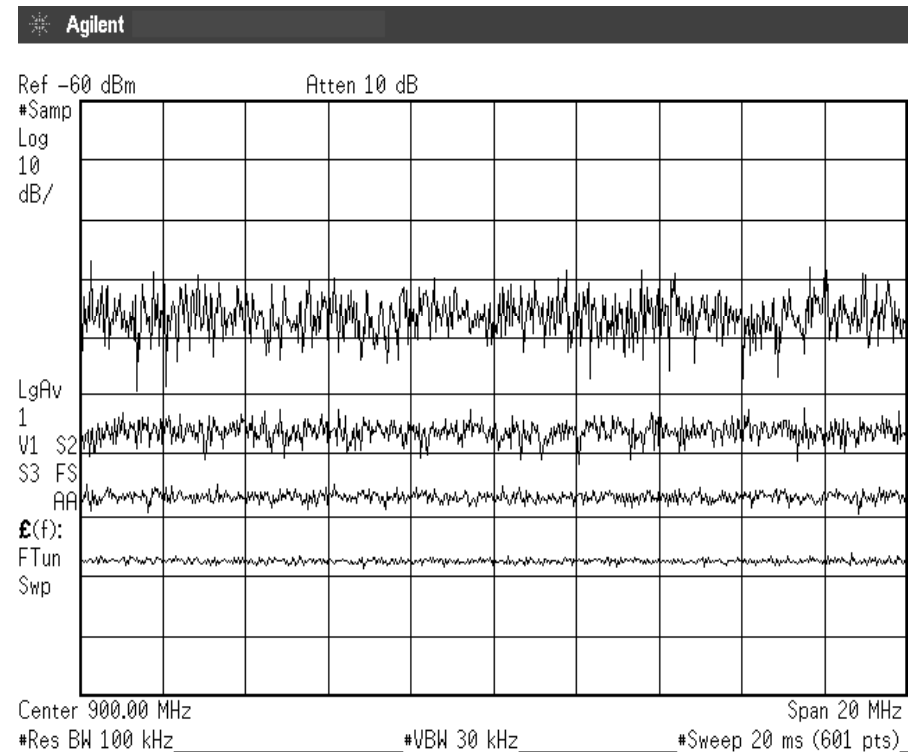

■ **Bibliography**

- S. Ciocina, *Masurari electrice si electronice*, 1999 ;
- [ham.elcom.pub.ro/iem](http://ham.elcom.pub.ro/iem);
- *Application notes* - National Instruments;
- J.G. Webster, *Electrical Measurement, Signal Processing and Displays*, 2004;